

Motorized Projector Lifts



This product adopts the asynchronous motor with slowdown & electro-magnetic brake, and cross scissor shaped design with electronic position-fixing. It possesses an attractive appearance, is smooth and quiet, has precise positioning, comprehensive functions, convenient installation, simple operation and high capacity. Can connect the “Crestron, AMX” directly to control the machine by central control or single control. It is widely used for projector, TV & video conferencing systems, large-conferencing systems, office, residence or any educational facility.

Features:

1. Orientation: Tolerance of orientation is limited within 1mm.
2. Low noise: Noise within 50 decibels.
3. Central controlled panel: It is easy to control and connect “Crestron, AMX” to control the machine by central control.
4. Exterior Design: Unique & attractive appearance.
5. High loading capacity: It can load heavier projectors than other products and has good safety factor.

Technical Parameters:

Projector Lift

1. Model 52305
2. Voltage: 220v 50Hz or 110v 60Hz
3. Power: 25w
4. Dimension: 310x310x210mm (LxWxH)
5. Loading Capacity: 20 Kgs
6. Travel Length: 100cm
7. Bottom Panel Dimension: 50cm x 50cm
8. Deadweight (including bottom panel): 27 kgs

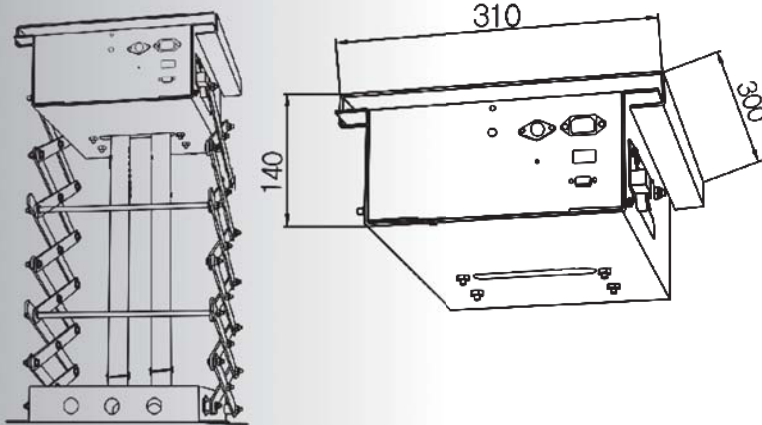

Electric Projector Lift	
Item #	Size of lift height
52305	100cm
52306	160cm
52307	200cm
52308	260cm
52309	360cm
52310	560cm
52395 low profile	100cm